



## M215 SIGNAL CONDITIONING M-MODULE

The M215 provides special purpose signal conditioning for low speed signals. It has two debounce channels designed to cleanup noisy switch contact closure signals and a very versatile quad window comparator function for monitoring voltage, current, or resistance.

The window comparators are isolated from logic ground to allow monitoring of floating sources, such as batteries or isolated UUT's. The window limits can operate in a fixed mode that requires no application programming or can be programmed through the M-module interface.

### Overview:

The M215 is specifically designed to provide special purpose signal conditioning functions. Debounce circuits can be used to level detect noisy or slow rising/falling signals. The window comparators can be used for voltage, current, or resistance monitoring of floating sources. The M-module trigger feed-through and isolated power source outputs are useful in general test applications.

#### Key Features:

- Two Signal Debounce Circuits With Differential Outputs
- Versatile Quad Isolated Window Comparator
- Programmable or Preset Window References
- External Voltage Ref. up to 30V
- Voltage Sensing up to 40V
- Current or Resistance Sensing
- Relay Driver Outputs
- Isolated Power Source
- Over-Voltage Protection on Inputs
- Bidirectional M-Module Trigger Function

#### Front Panel I/O:

- 44-Pin female (socket) DSUB right angle connector (CONEC part number 164A18119X or equivalent).
- Any standard 44-pin male (plug) DSUB connector will mate with it.

#### I/O Signals:

- EXTVA/B, ISENSEA/B, VSENSE
- F5VREF
- VSCALE1-0, SSCAL1-0, WSEL1-0
- +5VF, ±15VF
- GND, GNDF
- INW4SEL
- RLYOUT1-4, RLYOUTA-C
- RLYPWR
- DEBIN1-2, DEBOUT1-2+/-
- TRIGA-B

#### Power:

+5V	550 ma
+12V	0 ma
-12V	0 ma

#### Temperature:

Operating	0°C to 50°C
Storage	-40°C to 70°C

### M Module Compliance

Complies with ANSI/VITA Std. 12-1996 for single-wide M Modules

Data Transfers: 16 bit

M-Triggers Supported

Compatible with VXI, LXI, PXI, VME, PCI, cPCI, Ethernet and other M Module carriers.

### Applications

- Voltage/Current/Resistance Monitoring
- Signal Debounce

### Ordering Information

M215 M-Module 11029350-0001

### Additional Information

User Manuals for C&H carriers and this module can be found on our website at [www.chtech.com](http://www.chtech.com).

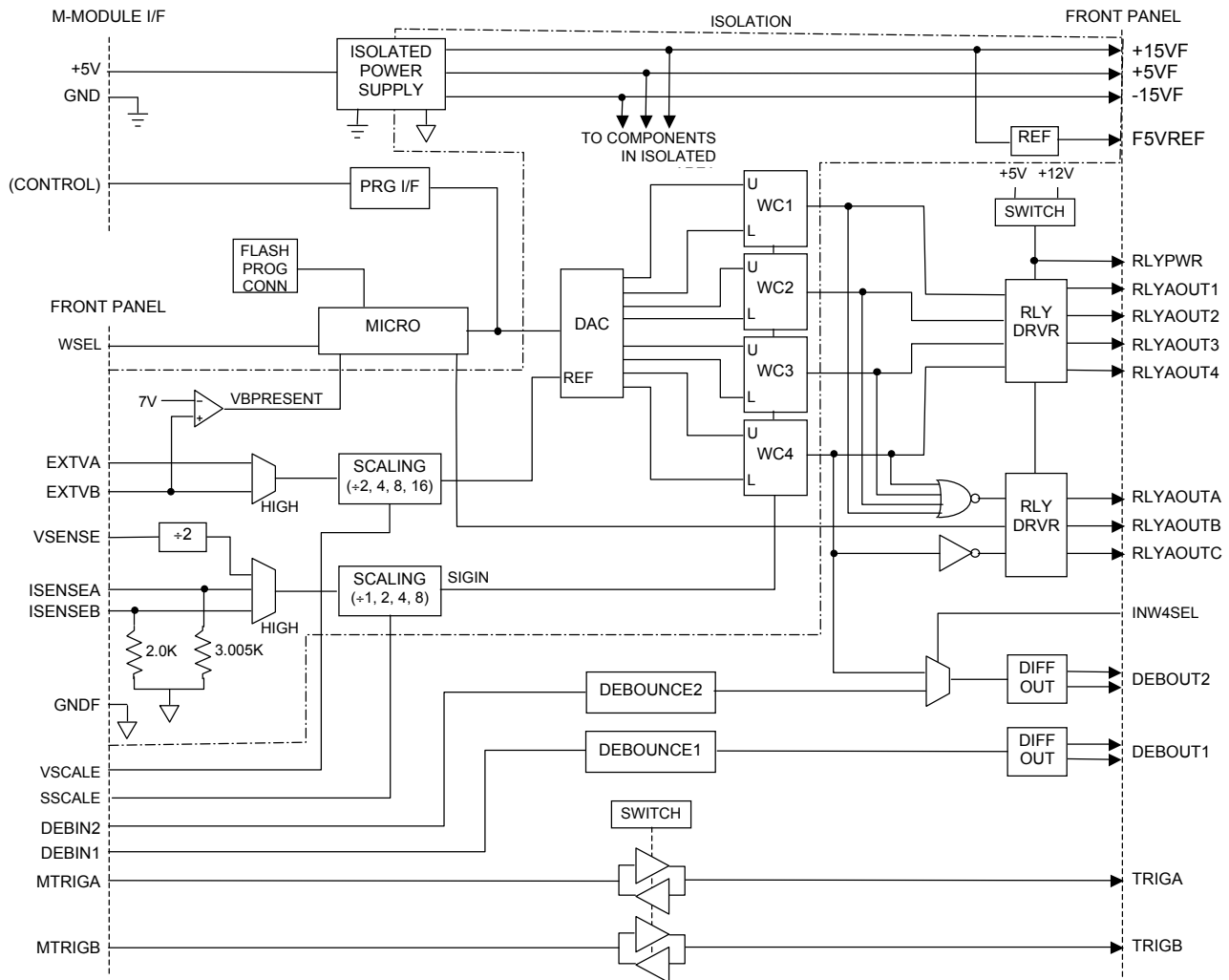

## Specifications:

### Debounce (DEBINx & DEBOUTx):

Input Pull-up Level (R=10K $\Omega$ )	+5V <sup>1</sup>
Threshold Level	+1.3V typ <sup>1</sup>
Debounce Time	30ms typ
Response Time <sup>3</sup> high going transition	18 $\mu$ s typ
low going transition	400ns typ

### External Reference Voltage (EXTVA/B)

Input Range	1.0 to 30V <sup>2</sup>
Scaling <sup>7</sup>	1 to 8

### Voltage Sense Input (VSENSE)

Input Range	0.5 to 40V <sup>2</sup>
Scaling <sup>7</sup>	2 to 16

### Current (Resistance) Sense Input (INSENSEA/B)

Input Range	ISENSEA	0 to 13.2ma
	INSENSEB	0 to 20.0ma
Scaling <sup>7</sup>		1 to 8
Accuracy	VRA, nom=3.005K $\Omega$	$\pm$ 1%
	VRB, nom=2.00K $\Omega$	$\pm$ 1%
Power	VRA & VRB	0.5W

### Differential Outputs

High Level Output	I <sub>OH</sub> =-40ma	2.0V min <sup>1</sup>
Low Level Output	I <sub>OH</sub> =-40ma	0.45V max <sup>1</sup>
Short Circuit Output		-90ma typ

### Relay Driver Outputs

Output Sink Current (continuous)	500ma <sup>4</sup>
RLYPWR Output +5V drive	450ma <sup>5</sup>
+12V drive	200ma <sup>5</sup>

### Floating Fixed References

Voltage Output	F5VREF (+5V nom)	$\pm$ 0.08%
Temp Coef		12 ppm/ $^{\circ}$ C max
Isolation Voltage		1000V min
Maximum Current		50ma

### Floating Output Supplies

Maximum Current	+5VF, $\pm$ 15VF	10ma <sup>6</sup>
Isolation Voltage		1000V min

### Notes:

- This level is with respect to GND.
- This level is with respect to GNDF.
- This time assumes that the signal has not changed level for at least the debounce time. After a change is detected, the input signal is ignored during the debounce time.
- Assumes external power is used.
- These maximum values are specified to meet the maximum current specifications specified in the ANSI/VITA 12-1996 M-Module specification.
- These supplies are provided for limited external use. The supplies are used internally; the maximum current specified must not be exceeded to ensure proper internal operation.
- Set through front panel connections