

U S E R ' S M A N U A L

ETHERNET
M-MODULE
CARRIER

MODEL
EM405-8

COPYRIGHT

C&H Technologies, Inc. (C&H) provides this manual "as is" without warranty of any kind, either expressed or implied, including but not limited to the implied warranties of merchantability and fitness for a particular purpose. C&H may make improvements and/or changes in the product(s) and/or program(s) described in this manual at any time and without notice.

This publication could contain technical inaccuracies or typographical errors. Changes are periodically made to the information herein; these changes will be incorporated in new editions of this publication.

Copyright © 2007, 2012 by C&H Technologies, Inc.

The information and/or drawings set forth in this document and all rights in and to inventions disclosed herein which might be granted thereon disclosing or employing the materials, methods, techniques, or apparatus described herein, are the exclusive property of C&H Technologies, Inc.

A Reader's Comment Form is provided at the back of this publication. If this form has been removed address comments to:

C&H Technologies, Inc.
Technical Publications
800 Paloma Drive, Suite 150
Round Rock, Texas 78665

C&H may use or distribute any of the information you supply in any way that it believes appropriate without incurring any obligations whatever.

DOCUMENT REVISION NOTICE

C&H Technologies, Inc. makes every attempt to provide up-to-date manuals with the associated equipment. Occasionally, throughout the life of an instrument, changes are deemed necessary to equipment related documentation. The latest revision of our documentation is available for download from our web site at <http://www.chtech.com>.

NOTE

The contents of any amendment may affect operation, maintenance, or calibration of the equipment.

INTRODUCTION

This manual describes the operation and use of the C&H Model EM405-8 Ethernet M-Module Carrier/Bridge (Part Number 11029380). This instrument is one of a number of M-Module carriers provided by C&H.

Contained within this manual are the physical and electrical specifications, installation and startup procedures, functional description, and configuration and programming guidelines to adequately use the product.

Software drivers for an installed M-Module may be provided by the M-Module manufacturer. Some drivers may require modification to operate correctly with the communication protocol and the addressing methodology used by the EM405-8. To support initial operation and application software development, C&H provides a software application called Interactive Mezzanine Control (IMC). The application provides immediate access and control of any M-module residing on an EM405-8. IMC can be downloaded from the support section of C&H's website www.chtech.com.

TABLE OF CONTENTS

1.0	GENERAL DESCRIPTION	1
1.1	PURPOSE OF EQUIPMENT	1
1.2	FEATURES AND SPECIFICATIONS	2
1.2.1	Key Features	2
1.2.2	Specifications	2
1.3	ELECTRICAL	4
1.4	MECHANICAL	4
1.5	ENVIRONMENTAL	4
1.6	BUS COMPLIANCE	5
1.7	APPLICABLE DOCUMENTS.....	5
2.0	INSTALLATION	6
2.1	UNPACKING AND INSPECTION	6
2.2	HANDLING PRECAUTIONS	6
2.3	INSTALLATION OF M-MODULES	6
2.4	REMOVAL OF M-MODULES.....	7
3.0	FUNCTIONAL DESCRIPTION	9
3.1	GENERAL	9
3.1.1	Embedded Controller	9
3.1.2	Ethernet Interface.....	10
3.1.3	USB Interface.....	10
3.1.4	PCI to Local Bus Bridge	10
3.1.5	M-Module Interface	10
3.1.6	Trigger Control	10
3.1.7	AC/DC Converter	10
3.1.8	DC/DC Converter	10
3.2	FRONT PANEL.....	11
3.3	REAR PANEL	12
4.0	OPERATING INSTRUCTIONS	13
4.1	GENERAL	13
4.2	DISCOVERY	13
4.3	WEB SERVER.....	13
4.4	CONFIGURING THE ETHERNET INTERFACE.....	14
4.4.1	TCP/IP Mode	15
4.4.2	IP Address.....	16
4.4.3	Subnet Mask.....	16
4.4.4	Gateway	16
4.4.5	Raw Socket	16
4.4.6	Raw Socket Port.....	16
4.4.7	Restoring Factory Defaults	17
4.4.8	Password	17
4.5	STATUS/CONTROL WEBPAGE	17
4.5.1	M-Module Information	18
4.5.2	Temperature	18
4.5.3	Fan Full On	18

4.5.4	Self Test Button	18
4.5.5	System Reset.....	18
4.5.6	Device Clear	19
4.6	COMMUNICATING WITH THE CARRIER AND M-MODULES	20
4.6.1	Error Handling	21
4.6.2	Write Data command.....	22
4.6.3	Read Data command.....	23
4.6.4	Block Access	23
4.6.4.1	Block Write command	25
4.6.4.2	Block Read command.....	26
4.6.5	EM405-8 Configuration/Status Registers.....	27
4.7	IVI AND M-MODULE DRIVERS	38
4.8	CONTROLLING THE TRIGGERS.....	38
4.9	FAN AND TEMPERATURE CONTROL	40

APPENDIX A - CONNECTORS A-1

LIST OF FIGURES

Figure 1.	EM405-8 Ethernet M-Module Carrier	1
Figure 2.	M-Module Configuration Diagram	7
Figure 3.	M-Module Installation.....	8
Figure 4.	M-Module Removal	8
Figure 5.	Functional Block Diagram	9
Figure 6.	Front Panel	11
Figure 7.	Rear Panel.....	12
Figure 8.	Web Home Page.....	14
Figure 9.	Web LAN Configuration Page	15
Figure 10.	Web Status/Control Page.....	19
Figure 11.	EM405-8 Registers.....	29
Figure 12.	Trigger Logic (Input Direction)	39
Figure 13.	Trigger Logic (Output Direction).....	39
Figure A-1.	LVDS Micro-D Connector.....	A-1
Figure A-2	DC Input Connector	A-1

LIST OF TABLES

Table I.	Command Summary	20
Table II.	Status Code (SC).....	21
Table III.	Register Summary	27

1.0 GENERAL DESCRIPTION

The EM405-8 easily bridges up to eight (8) standard M-Modules to a typical Ethernet (LAN) network. The carrier provides full access to the M-Module I/O space via the standard TCP/IP networking protocol. The EM405-8 uses a standard method of device discovery, easy configuration through an intuitive web interface, and a standard IVI driver for communication with the controller.

The -0001 and -0003 versions support M-Module triggers allowing them to connect to any other installed M-Modules or to an external device. These versions support both TTL and LVDS signal levels. A simple command structure eases software integration and allows reset, identification, control, and configuration of the carrier and M-Modules. For a complete list of M-Modules compatible with the EM405-8 carrier, visit the Support section on C&H's website (www.chtech.com).

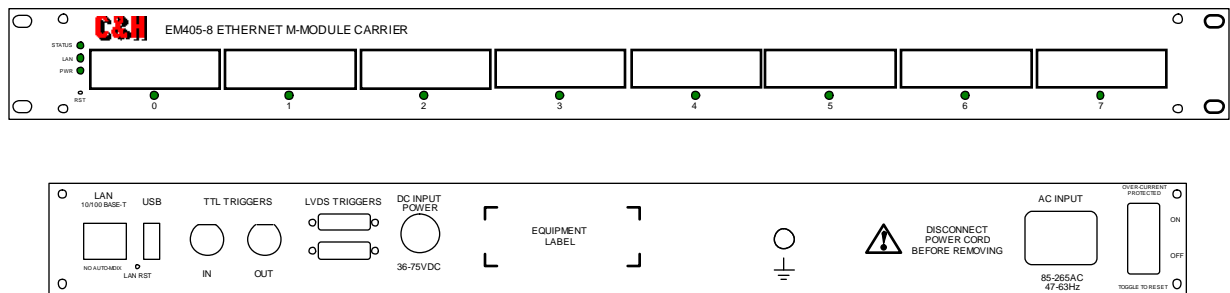

Figure 1. EM405-8 Ethernet M-Module Carrier

1.1 PURPOSE OF EQUIPMENT

The EM405 easily interfaces a VITA 12-1996 standard M-Module to a typical Ethernet network. The carrier allows the numerous functions available in the M-Module mezzanine format to be remotely located near the unit-under-test, easing many system integration issues. Over 100 M-Modules are available from numerous manufacturers.

WARNING: This product is not designed for use in explosive environments.

1.2 FEATURES AND SPECIFICATIONS

1.2.1 Key Features

- Supports eight ANSI/VITA 12-1996 compliant single-wide M or MA-modules or a combination of double or triple-wide modules
- Ethernet 10Base-T, 100Base-TX (Auto-Sensing)
- Rugged steel/aluminum 19 inch rack mount 1U High enclosure
- AC Input 85-265VAC, 47-63Hz (accepts standard IEC 320-C13 power cords)
- Alternatively powered by an external +48VDC (5-pin circular DIN connector)
- Forced air cooling with software temperature status monitoring
- IVI driver provides control of the EM405-8 bridge functions
- Configuration through an intuitive web interface
- Flexible block access command provides rapid sequential and FIFO data accesses
- External and inter-module triggers supported (-0001/3 versions only)
- Isolated and filtered +5V, +12V, and -12V supplies for each M-Module
- Power-off reset-able breakers provided for each M-Module position

1.2.2 Specifications

MAXIMUM RATINGS

Parameter	Condition	Rating	Units
Operating Temperature		0 to +60	°C
Non-Operating Temperature		-40 to +75	°C
Humidity	non-condensing	5 to 95	%
DC Input Voltage Level		75	V max.
DC Input Surge Voltage	100ms	100	V max.
AC Input Protection	rocker switch	4	A max.
Input Power Consumption	with 8 M-Modules at 10W each	100	Watts
Total M-Module Current (total for all eight positions)	+5V	8.0	A
	+12V	1.6	A
	-12V	1.6	A
M-Module Current (each position, total for all M-Modules can not exceed Total M-Module Current)	+5V	2.0	A
	+12V	900	mA
	-12V	900	mA
External TTL Trigger Input (-0001/3 versions only)	Power Off	± 40	V
	Power On	± 36	V

CHARACTERISTICS

Parameter	Conditions	Limit			Units
		Min	Typ.	Max	
Data Transfers					
Throughput	Ethernet – block read ^{1,3}		400K	450K	bytes/sec
	Ethernet – block write ^{2,3}		300K	350K	bytes/sec
AC Input Power (IEC 320-C13)					
Level	AC	85		265	V
Power Consumption	for full M-Module support			100	W
DC Input Power (DIN Connector)					
Level	DC	36	48	75	V
Power Consumption	for full M-Module support			100	W
Power Consumption					
Carrier (internal logic)	-0001/3 with trigger support			25	W
	-0002 without trigger support			22	W
Triggers (-0001/3 version only)					
Maximum Frequency				40	MHz
Minimum Pulse Width	Driven Mode				
	≤10 meter connection segment	10			ns
	≤20 meter connection segment	20			ns
	Wired-OR Mode				
≤10 meter connection segment	20			ns	
≤20 meter connection segment	40			ns	
Intermodule Trigger Delay	M-module to M-Module		21	27	ns
Intermodule Skew	M-module to M-Module		3	6	ns
TTL Trigger Delay	External BNC connector to M-Module		22	28	ns
	M-module to external BNC connector		24	30	ns
LVDS Trigger Delay	External connector to M-Module		20	26	ns
	M-module to external connector		20	26	ns
BNC Output Level	into a high impedance load	3.8	5.0	5.4	V
BNC Output Impedance			50		Ω
BNC Input Level	TLVL = 0 ⁴		2.5		V
	TLVL = 1		1.4		V
BNC Input Impedance	TIMP = 0 ⁴	900K	1M		Ω
	TIMP = 1		50		Ω
LVDS Differential Output	Magnitude	480		650	mV
LVDS Differential Input (Type 1 receiver)	Threshold, positive-going			50	mV
	Threshold, negative-going	-50			mV
	Hysteresis		25		mV
Cooling					
Temperature Rise				20	°C
Temperature Accuracy		-1		+1	°C

Notes:

- Several milliseconds of overhead and latency occur on each command issued. The effect of this overhead and latency is reduced by transferring large amounts of data with a single block read command. Maximum read throughput is achieved by reading >4K bytes of data from a FIFO type register on an M-Module using the Block Read command. Host software may vary and can limit the maximum throughput.
- The maximum number of bytes that can be written in a single block write command is 1024.
- Ethernet is a non-deterministic communications interface. Realized throughput may be significantly degraded by network activity or other factors that may affect network performance.
- TLVL and TIMP refer to register bits in the *TTL Trigger Control* register. Refer to section 3.6.5.

1.3 Electrical

The EM405-8 can be operated from AC or DC power. The AC input accepts an industry standard IEC 320-C13 power cord and automatically accepts an AC level between 85 and 265V (47-63Hz). The power ON/OFF switch serves as an overload protection device. Toggling the switch through the OFF position and back ON will reset the mechanism. The AC power is converted to +48VDC for internal usage. Alternatively, the EM405-8 can be powered directly by an external +48VDC (nominal) power supply. The external connector mates to a 5-pin circular DIN male connector. See Appendix A for connector pin outs. The +48VDC power is subsequently converted to +5V, +3.3V, +12V, and -12V to be used by the internal logic and M-Modules.

Isolated and filtered +5V, +12V, and -12V supplies are provided to each M-Module position. In addition, each position has separate power-off reset-able breakers for each voltage level supplied. If a fault occurs, power must be removed from the EM405-8 before the breaker will reset. The breakers are rated at 2.5 amps for the +5V power and 1.25A for the +12V and -12V power. This allows usage of M-Modules that exceed the ANSI/VITA Std. 12-1996 specification for power consumption; however, the total M-Module power consumption is limited to 8A for the +5V supply and 1.6A each for the $\pm 12V$ supplies. The ANSI specification allows a maximum of 1A for the +5V supply and 200mA each for the $\pm 12V$ supplies for a single M-Module.

1.4 Mechanical

The EM405-8 is contained in a 19 inch rack mount 1U high metal chassis with an outside dimension of 19.0 inches wide by 12.2 inches deep by 1.72 inches high. A series of fans provide forced air for cooling the M-Modules and the carrier electronics. The unit weighs approximately 9 lbs with no M-Modules installed.

1.5 Environmental

The environmental specifications of the module are:

Operating Temperature:	0°C to +60°C*
Storage Temperature:	-40°C to +75°C
Humidity:	<95% without condensation

* The forced air cooling is designed to allow a maximum 20°C temperature rise for installed M-Modules. In other words, with eight M-Modules operating at full dissipation (10W each), the M-Modules' temperature can only be maintained within 20°C of the ambient air inlet temperature. Installed M-Modules may differ in environmental specifications. Refer to individual M-Module's documentation for more information.

1.6 Bus Compliance

The carrier complies with the ANSI/VITA 12-1996 Specification for single or double-wide M-Modules and the MA-Module trigger signal extension.

Addressing:	A08 only (extended addressing not supported)
Data:	D16 only
Interrupts:	not supported
DMA:	not supported
Triggers:	Trig A and Trig B Input/Output (-0001/3 version only)
Manufacturer ID:	0FC1 ₁₆
Model Number:	0FD9 ₁₆

1.7 APPLICABLE DOCUMENTS

ANSI/VITA 12-1996 American National Standard for The Mezzanine Concept M-Module Specification, Approved May 20, 1997, VMEbus International Trade Association, 7825 E. Gelding Dr. Suite 104, Scottsdale, AZ 85260-3415, E-mail: info@vita.com, www.vita.com

IEEE-802.3 (ANSI 8802.3) Ethernet Network Standard

INSTALLATION

1.8 UNPACKING AND INSPECTION

Verify that there has been no damage to the shipping container. If damage exists then the container should be retained, as it will provide evidence of carrier caused problems. Such problems should be reported to the carrier immediately as well as to C&H. If there is no damage to the shipping container, carefully remove the instrument from its box and inspect it for any signs of physical damage. If damage exists, report immediately to C&H.

1.9 HANDLING PRECAUTIONS

The components used in the EM405-8 are static sensitive. Damage may occur if proper static precautions are not taken. Installation of M-Modules should only be done at a properly grounded static free workstation.

CAUTION: Read the entire User's Manual before proceeding with the installation and application of power.

1.10 INSTALLATION OF M-MODULES

To install modules, first remove power from the carrier. Remove the top cover by removing the six screws located on the top cover. Do *not* remove the screws located on the front and rear connector panels. There are eight M-Module mounting locations on the EM405-8 as illustrated in Figure 2. Install the modules by firmly pressing the connector on the M-Module together with the connector on the carrier as shown in Figure 3. Care must be exercised to ensure the pins are properly aligned. See “WARNING” and “CAUTION” below. Secure the module through the holes in the bottom of the enclosure using screws provided with the M-Module. Replace the top cover before applying power.

WARNING: The EM405-8 supports M-Modules that use two or three row interface connectors. When using M-Modules with only two rows, row C of connector (rear row) is left unconnected.

CAUTION: M-module connectors are NOT keyed. Use extra caution to avoid misalignment. Applying power to a misaligned module can damage the M-Module and carrier.

1.11 REMOVAL OF M-MODULES

To remove an M-Module, first remove all four screws from the holes in the bottom of the enclosure. Do NOT remove the screws from the top of the M-Module. With several fingers of one hand, apply an upward pressure to the back of the mating connector. With your other hand, slowly rock the module from side to side. The module should slowly loosen itself from the carrier header pins. If the EM405-8 is completely full, a pointed prying bar may be required to help remove the first module. The point of the prying bar can be placed between the carrier header and the M-Module to loosen the connection as shown in Figure 4.

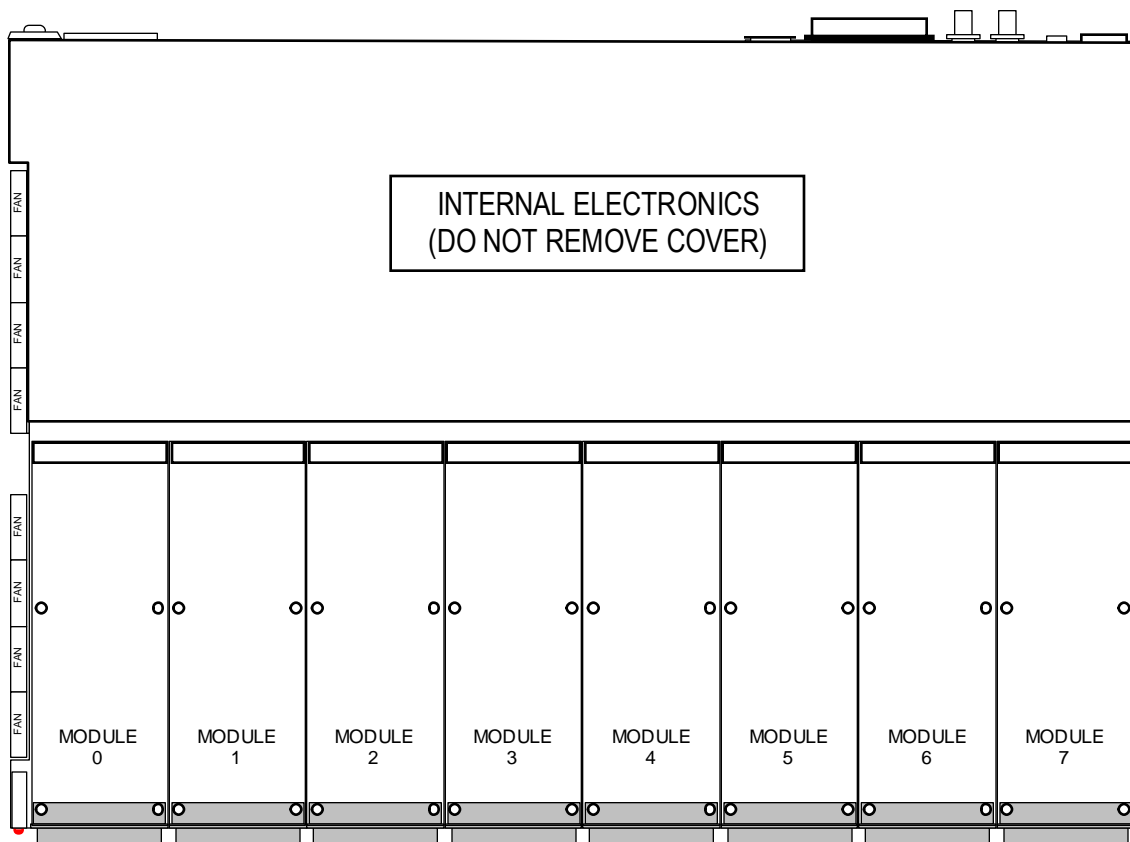

Figure 2. M-Module Configuration Diagram

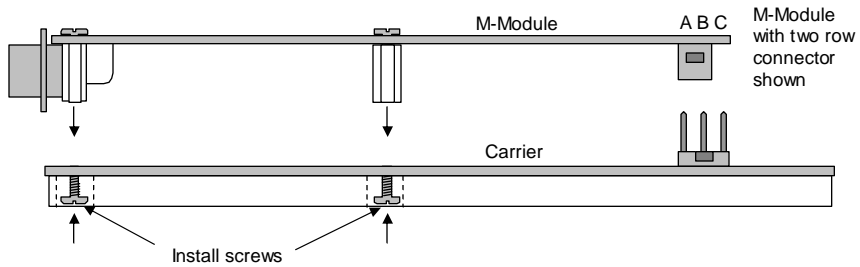

Figure 3. M-Module Installation

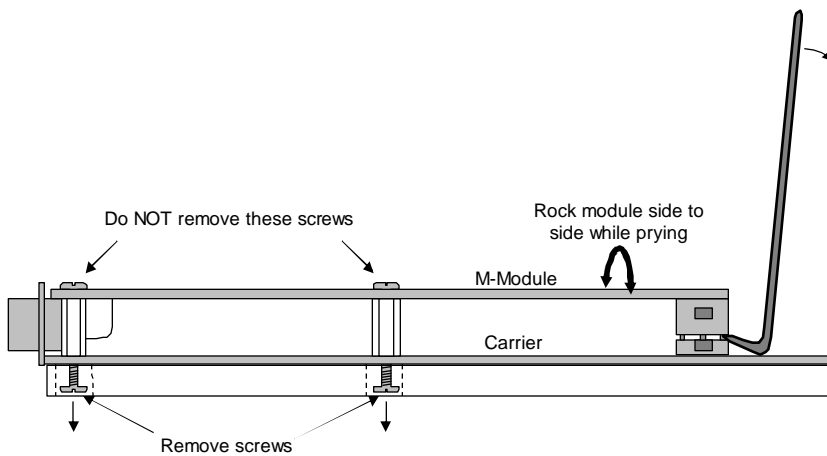

Figure 4. M-Module Removal

2.0 FUNCTIONAL DESCRIPTION

2.1 GENERAL

The EM405-8 provides a mechanical and electrical interface between an Ethernet bus and up to eight M-Modules. It utilizes an embedded microcontroller to provide buffering and command translation between the Ethernet interface and the M-Modules. A simplified functional block diagram is shown in Figure 5.

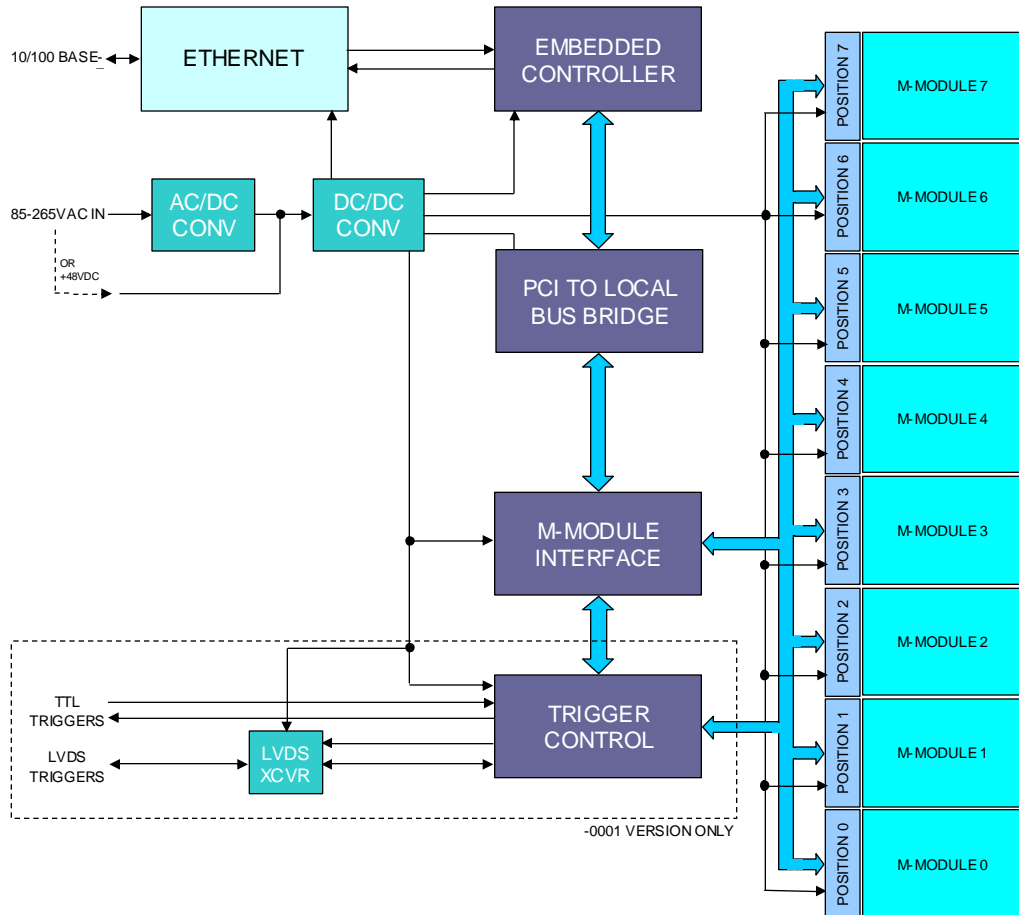

Figure 5. Functional Block Diagram

2.1.1 Embedded Controller

The embedded controller is implemented using a high-performance microprocessor module. The microcontroller executes system firmware that controls the translation between Ethernet and the M-Module interface. The system firmware implements a simple command protocol that allows access to the M-Modules I/O space, trigger mapping and carrier information and status.

2.1.2 Ethernet Interface

The Ethernet interface provides the physical and logical connection to the EM405-8 allowing remote control of the M-Modules. The EM405-8 provides a 10/100 Base-T Ethernet connection for communication purposes. The interface supports the TCP/IP protocol for control of the M-Modules. It also supports DHCP, Telnet, and other standard protocols for device configuration and management.

2.1.3 USB Interface

The USB interface is used for development purposes only. The USB interface is fully compatible with USB specification version 1.1 and supports both 12 Mbps and 1.5 Mbps transfer speeds.

2.1.4 PCI to Local Bus Bridge

The PCI to Local Bridge provides the interface between the embedded controllers PCI bus and the M-Module and Trigger control logic.

2.1.5 M-Module Interface

The M-Module interface provides the mechanism for the microcontroller to access the M-Modules. It is implemented using programmable logic that emulates a bridge between the microcontroller and the M-Module bus.

2.1.6 Trigger Control

The trigger control logic provides control of the intermodule triggering, the TTL Triggers, and the LVDS triggers. It is implemented using programmable logic. The trigger control logic is only available on the -0001 and -0003 versions.

2.1.7 AC/DC Converter

The AC input power is converted to the +48VDC power for subsequent conversion to levels required by the carrier and the M-Modules.

2.1.8 DC/DC Converter

The +48VDC power is converted to +5V, +3.3V, +12V, -12V, and other levels required by the onboard carrier logic and the M-Modules.

2.2 FRONT PANEL

The front panel of the EM405-8 contains eight openings for access to the M-Modules' front panel connections as shown in Figure 6. Below each opening is an LED indicator that indicates an access to that M-Module. The LED will illuminate temporarily each time the module is accessed by the host software. On the far left side, below the PWR indicator, access to the carrier reset switch is provided through a small pinhole. To reset (reboot) the carrier, momentarily depress the switch using a small round object such as a bent paper clip. There are three LED indicators on the left side of the front panel. The functions of these indicators are:

STATUS: indicates a self-test failure.

LAN: indicates the status of the LAN interface.
Solid On Green – Normal operation
Flashing Green – Device Identify
Solid On Ready – LAN Fault (see list below)

PWR: indicates that +48V internal power is present.

Potential LAN faults include:

1. Failure to acquire a valid IP address
2. Detection of a duplicate IP address
3. Failure to renew an already acquired DHCP lease (failure to obtain an initial DHCP lease is not a failure)
4. LAN cable disconnected

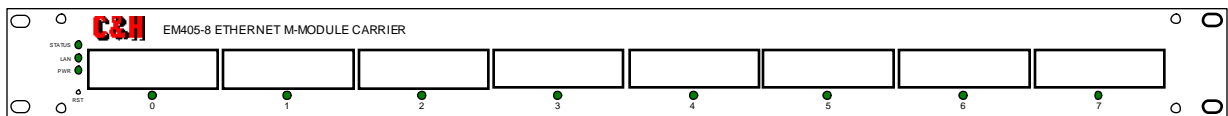

Figure 6. Front Panel

2.3 REAR PANEL

The rear panel of the EM405-8 contains connectors for the Ethernet and USB interfaces, TTL and LVDS triggers (-0001/3 versions only), and AC or DC input power. An AC power switch/breaker is available on the far right side and a LAN reset access hole is available below the LAN connector. The LAN reset switch allows reset of the Ethernet configuration to factory default values. See section 3.4.7 for details. A grounding stud/nut is also provided for connection of the chassis to a suitable equipment ground. Refer to Appendix A for pin-out details of the LVDS and DC input power connectors.

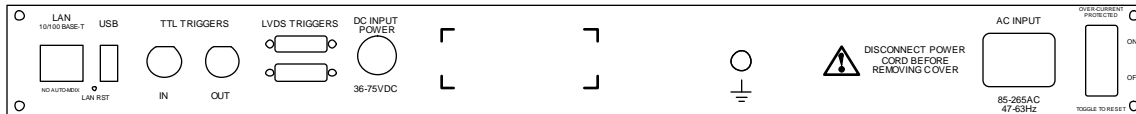

Figure 7. Rear Panel

3.0 OPERATING INSTRUCTIONS

3.1 GENERAL

The EM405-8 is controlled through the Ethernet interface using the TCP/IP protocol to carry a simple command structure to the module. The carrier contains a set of software controlled registers that allow the user to request status from the carrier, identify the carrier, and configure the carrier. All other M/MA controls are dependent on the specific M-Module(s) that reside on the carrier.

The EM405-8 uses a standard Ethernet I/O communication protocol. The Ethernet interface must be properly configured to work on the user's network. The flexibility of the EM405-8's Ethernet interface allows it to be used in a large number of possible network configurations. The unit is delivered with a default configuration that may or may not be appropriate for the user's network. It is up to the user and the user's network administrator to use the information provided throughout this section to determine what configuration is best for the given network.

3.2 DISCOVERY

The EM405-8 supports the VXI-11 protocol for device discovery and communication. This allows any VXI-11 based discovery utility to discover the EM405-8 on the user's network without the requirement of knowing the EM405-8's current IP address. VXI-11 discovery utilities are generally included with the VISA I/O library package provided by several third-party vendors.

The EM405-8 allows for one network link per installed M-Module, plus one network link for the carrier itself. Therefore, it is likely that the discovery utility will discover several instruments at the same IP address. For example, if the carrier is fully populated with 8 M-Modules, the device discovery utility may discover 9 instruments at the IP address of the EM405-8.

3.3 WEB SERVER

To use the EM405-8's web interface, open a web page at the device's IP address. This can be done using any W3C compliant browser, such as Windows Internet Explorer or Mozilla Firefox. Enter the IP address as:

`x.x.x.x (i.e. 192.168.1.225)`

The first (Home) page provides instrument details such as the instrument model, manufacturer, serial number, description, hostname, MAC address, TCP/IP address, and firmware revision, as shown in Figure 8. The Home page also allows you to find the physical device associated with a particular IP address by clicking the Device Identify button. During identification, the LAN Status indicator on the front panel of the EM405-8 will blink rapidly. The indicator will continue to blink until the Stop Identifying button is pressed.

From the Home page, the LAN configuration and Status/Control pages can be accessed using the links in the navigation menu. These pages are discussed later.

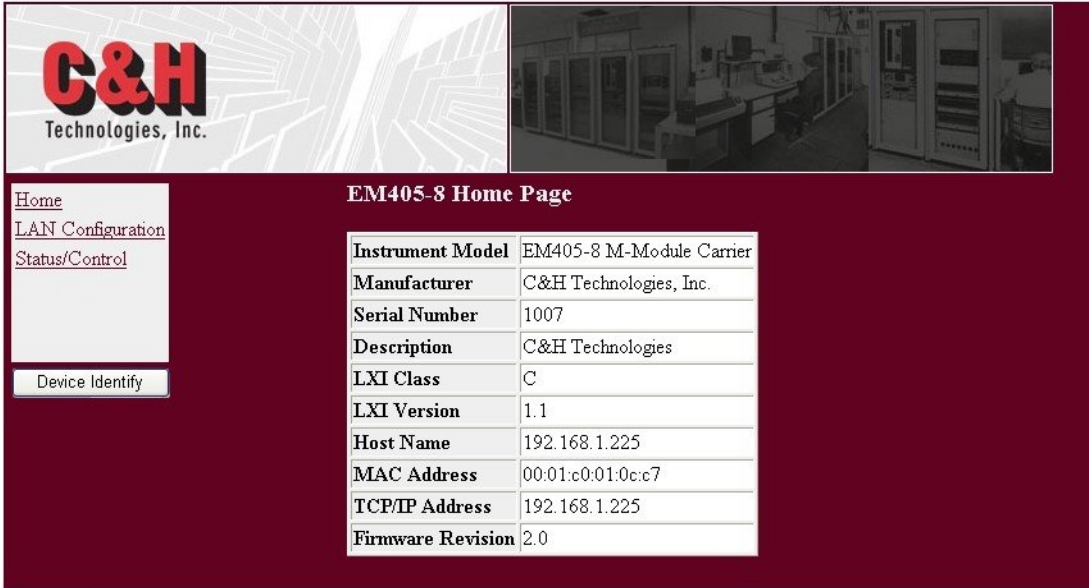

Figure 8. Web Home Page

3.4 CONFIGURING THE ETHERNET INTERFACE

Network configuration of the EM405-8 is performed through the LAN Configuration page of the web interface. To view the LAN Configuration page, select the LAN Configuration link from the navigation menu found on the left side of all EM405-8 web pages.

The LAN Configuration page is shown in Figure 9. From this page, the user can configure the IP configuration mode, IP address, subnet mask, default gateway, and the raw socket utility. Each of these is discussed further in the following sections.

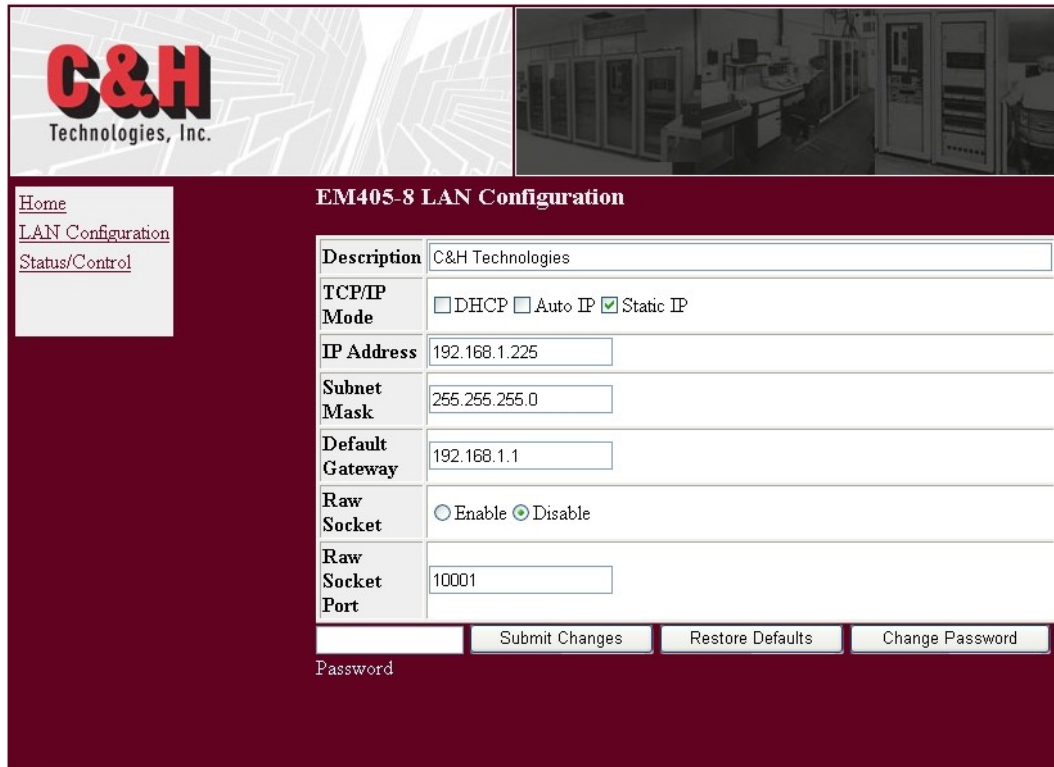

Figure 9. Web LAN Configuration Page

3.4.1 TCP/IP Mode

The EM405-8 must have a unique IP address before it can communicate on a network. There are several options for assigning an IP address to the unit. The option to choose is dependant upon the type of network for which the EM405-8 is being configured.

DHCP: The Dynamic Host Control Protocol (DHCP) allows the module to dynamically retrieve an IP address from a DHCP server at power-up. If DHCP is used, the EM405-8 may have a different IP address assigned each time it is powered on or connected to the network. DHCP requires that another device on the network is acting as a DHCP server. Otherwise DHCP will fail and the IP address of the EM405-8 will not be properly configured.

Auto IP: Auto IP utilizes the Dynamic Link-Local Addressing protocol to acquire an IP address. When performing Auto IP configuration, the device selects an IP address from a defined range of 169.254.0.0 to 168.254.255.255. It then performs an Address Resolution Protocol (ARP) query to determine if the selected IP address is being used by any other devices on the network. If it is free then the devices uses this IP address. If it is in use, the device selects another address from the range. It repeats this process until an unused IP address is found. Auto IP is useful on networks in which dynamic configuration is required yet a DHCP server does not exist.

Static: Static IP addressing allows the user to specify an IP address. The configured IP address will remain static even after power is removed from the module. For proper operation, the IP address must be chosen according to the network that the module is being connected to.

If more than one mode is enabled, the device will attempt to acquire an IP address using the enabled modes in the following order: 1) DHCP, 2) Auto IP, & 3) Static. Once an IP address is successfully configured, the device will stop the configuration.

The default IP configuration mode is: DHCP enabled, Auto IP enabled, Static disabled

3.4.2 IP Address

The IP Address field is only used if the Static IP configuration mode is selected. If the IP address was acquired using DHCP or Auto IP, this field represents the current IP address of the device.

3.4.3 Subnet Mask

The subnet mask defines the number of bits that are taken from the IP address to refer to the given network subsection. The subnet mask allows Ethernet based networks to be separated into various subnets. The EM405-8 should be in the same subnet as the controlling PC or router.

The default subnet mask is: 255.255.255.0

3.4.4 Gateway

The gateway address allows the EM405-8 to communicate with other network segments. If communication outside of the given network segment is necessary, the gateway address should be set to the IP address of the router connecting the local network segment to the outside world. The gateway address, if needed, must be within the local network.

The default gateway address is: 192.168.1.1

3.4.5 Raw Socket

Standard communication with the EM405-8 is performed using the VXI-11 protocol which is always enabled. Alternatively, the EM405-8 implements a raw socket method of performing device communications. By default, the raw socket method is disabled; however, it may be enabled using this control.

The default raw socket setting is: disabled

3.4.6 Raw Socket Port

If raw socket support is enabled, a TCP port must be specified. This port number must then be used for all raw socket communications with the EM405-8. Port numbers are assigned by the

Internet Assigned Numbers Authority (IANA) and many are reserved for specific functions such as http, smtp, or telnet. Care must be taken not to choose a port number that is reserved or that will be commonly used on the network.

Note that for the VXI-11 protocol, the port number is dynamically determined. Therefore, port configuration is not required for VXI-11 communication. Also VXI-11 communication is always enabled.

The default port number for standard module access is: 10001

3.4.7 Restoring Factory Defaults

There are two ways to restore the EM405-8 to its default configurations. From the LAN configuration web page, the user can enter the correct password and select the “Restore Defaults” button. Note that this will not restore the password to its default value.

Alternatively, the user can restore the configuration to defaults by depressing the LAN reset switch accessible via a pinhole found just below the LAN connector on the rear panel. Use a small round object, such as a bent paper clip, to access the switch. The switch must be held depressed until the LAN LED on the front panel goes from solid green to flashing. The flashing LED indicates that the system firmware has recognized the reset condition. Upon releasing the button, the settings will be reset to factory defaults. Unlike, the “Restore Defaults” button, the LAN reset switch will reset the password back to its default.

3.4.8 Password

A password is required to modify any of the network configurations. Make sure the correct password is entered in the Password box prior to selecting “Submit Changes” or “Restore Defaults.”

The user may change the password by selecting the “Change Password” button. The current password must be known in order to change the password.

The default password may be restored by performing a LAN reset using the LAN reset switch on the back of the EM405-8. Selecting the “Restore Defaults” button will not restore the default password.

The default password is: admin

3.5 STATUS/CONTROL WEBPAGE

The Status/Control webpage provides information on the M-Modules residing on the carrier, displays the current temperature as read from the three internal temperature sensors, and allows the user to control a few functions of the carrier such as turning the fans to full on and running self test. A screenshot of this webpage is shown in Figure 10.

3.5.1 M-Module Information

At power-up, the EM405-8's firmware attempts to identify each M-module residing in the 8 M-Module slots. Based on identification information provided by a module during the identification query, the firmware searches a database of known M-Modules to provide data on the function and manufacturer of the module. Since not all M-Modules provide identification information, some installed modules may indicate "Unknown". The lack of this information does not prevent normal operation of an M-Module. In addition, some installed M-Module may not use the M-Module interface for register communication. The slot will indicate "empty" for those types of modules.

3.5.2 Temperature

The three temperature sensors are read once whenever this page is refreshed, and the value is stored in the temperature table on this page. The name of each temperature sensor is indicative of where, internally, the sensor is located. The Fan Intake sensor is located near the fans on the left side of the enclosure. The M-Module Area sensor is located in the middle of the carrier underneath the M-Modules. The Logic Area sensor is located towards the back right corner of the carrier near where the bulk of the carrier logic resides.

If the Automatic Refresh box is selected, this web page will automatically refresh every 10 seconds.

3.5.3 Fan Full On

If the Fan Full On check box is selected, the fans on the EM405-8 will run at full speed. If the Fan Full On is not selected, the fans will be set to run at a variable speed where the firmware constantly monitors the temperature and speeds up the fans if the temperature rises above a set limit. The fan operational mode, full on or variable speed, is retained during power-off. Refer to Section 3.9 for details on the fan and temperature sensors.

3.5.4 Self Test Button

The Self Test button will cause the EM405-8 to run its internal self test. The self test may take up to 10-15 seconds to run during which time the Status/Control webpage will be set to refresh. Once self test is complete, the status will be displayed on the web page. Note the self test does access the M-Module positions; therefore, it is possible that it will modify the configuration of the M-Module and thus interfere with any applications that are using the M-Modules.

3.5.5 System Reset

The System Reset button will cause the EM405-8 to reboot and reset all M-Modules. The LAN interface is brought down, and then re-started during reboot. The LAN configuration is not reset. To reset the LAN configuration to factory default, refer to Section 3.4.7.

3.5.6 Device Clear

The Device Clear button initializes the VXI-11 interface. If instruments are opened, but not closed properly, system resources may become unavailable. The Device Clear button clears all VXI-11 resources and allows new resources to be opened.

C&H Technologies, Inc.

Home
LAN Configuration
Status/Control

EM405-8 Status/Control

M-Module Information (Database Version: 1.0)

Slot	IDENT	Model	Function	Revision	Manufacturer
0	00D6	M214	Prec DC Reference	10	C&H Tech
1	00CC	MA204	Pulse Generator	2	C&H Tech
2					
3	0686	M218	Form A Switch	2	C&H Tech
4					
5	00C8	MA200	Aperture A/D	2	C&H Tech
6	069A	M223	Digital I/O	2	C&H Tech
7					

Temperature (°C)

Fan Intake	27.8
M-Module Area	25.5
Logic Area	27.2

Automatic Refresh
 Fan Full On

Run Self Test Self Test Passed [0]
System Reset
Device Clear

Figure 10. Web Status/Control Page

3.6 COMMUNICATING WITH THE CARRIER AND M-MODULES

The EM405-8 implements two protocols for transferring commands and data over the Ethernet bus. The VXI-11 protocol is the default method of communication. It is always enabled and always active. VXI-11 uses the ONC Remote Procedure Call (RPC) model for defining instrument messages. The host-side software must also implement VXI-11 to perform communication. Most VISA I/O implementations implement the VXI-11 protocol for TCPIP INSTR resource types. Alternatively, raw socket communication can be enabled and used for communications. By default, raw socket communication is disabled. In raw socket communication, the messages and data are passed directly within the TCP protocol layer and therefore special protocols are not required.

Regardless of the encapsulating protocol, the messages and data that the EM405-8 uses is based on a simple binary command structure. The commands allow the user to either write or read registers residing on the EM405-8 or on each M-Module. By writing registers residing on the EM405-8, the user can identify the module, perform device configuration, and receive status. The registers residing on each M-Module are specific to the particular M-Module. Refer to the M-Module's documentation for register details.

Each command consists of a command-id byte, a module number on which the command is to be executed and parameters, if required. The commands are listed in Table I. Details of each command are found throughout the rest of this section.

Table I. Command Summary

Binary Command-id	Function
0x20	Write Data
0x30	Read Data
0x45	Block Write
0x55	Block Read

3.6.1 Error Handling

Each command will return a status code as the last byte in its response. This status code will indicate whether the command completed successfully or whether an error occurred while the EM405-8 was performing the command. Table II shows a list of potential status codes that may be returned.

Table II. Status Code (SC)

Value	Meaning
0x00	Successful
0x01	Invalid Command
0x02	Invalid Parameter
0x03	Module did not respond*

* Note: Applies to M-Module requests only.

Successful (0x00): The command completed successfully without error.

Invalid Command (0x01): The first byte received was not a valid command-id value from the list in Table I.

Invalid Parameter (0x02): The EM405-8 received a valid command however the command could not be completed because one of the command parameters was invalid or out of range. Refer to the description of each individual command for parameter details.

Module Did Not Respond (0x03): The EM405-8 received a valid command with valid parameters; however, the specified module did not respond to the access. This error code applies to M-Module accesses only. The error code could result from the specified M-Module being absent, the specified address being outside the range of addresses supported by the particular M-Module, or more serious hardware problems with the M-Module itself.

If any of the above status codes are returned, the EM405-8 will set the *Reset Error (RERR)* status bit in the EM405-8 *Reset Error and Manufacturer ID* register (refer to section 3.6.5 for details on this register). The *RERR* bit can be cleared by writing a '1' to that bit location in the *Reset Error and Manufacturer ID* register. The status is provided only to indicate that an error has occurred. Normal operation is NOT inhibited.

Driver software should be written such that it checks for error conditions and performs the appropriate action to reset the RERR bit. In most cases error conditions are generated by errors in the software source code, therefore, once the software has been debugged and verified, error codes will rarely, if ever be received.

3.6.2 Write Data command

The Write Data command writes data to an EM405-8 control register or to a register residing on an M-Module. The command consists of seven bytes including the command-id, the module to which the data should be written, an address space selector, the access width, the address, and two data bytes. The return value consists of a single status byte.

Command Syntax:

0x20 md as ws ad dh dl

Return:

SC

where

md = module (0 = EM405-8 control, 1 = M-Module 0, 2 = M-Module 1, ...)

as = address space (0 = I/O, 1 = future use)

ws = word size (2 = 16-bit word, other values for future use)

ad = address (0 to FF)

dh = data (MSB)

dl = data (LSB)

SC = Status Code

Example (values shown hex):

To write the data value 0x1234 to M-Module 0, send the following command:

Command: cd md as ws ad dh dl

Send: 20 01 00 02 06 12 34

Receive: 00 (if successful)

3.6.3 Read Data command

The Read Data command reads data from an EM405-8 control/status register or from a register residing on an M-Module. The command consists of five bytes including the command-id, the module from which the data should be read, as address space selector, the access width and the address from which to read. The return value consists of two data bytes followed by a single status byte.

Command Syntax:

0x30 md as ws ad

Return:

dh dl SC

where

md = module (0 = EM405-8 control, 1 = M-Module 0, 2 = M-Module 1, ...)

as = address space (0 = I/O, 1 = future use)

ws = word size (2 = 16-bit word, other values for future use)

ad = address (0 to FF)

dh = data (MSB)

dl = data (LSB)

SC = Status Code

Example (values shown hex):

To read the Device Identification Register on the EM405-8, send the following command:

Command: cd md as ws ad

Send: 30 00 00 02 02

Receive: 0F DB 00 (if successful)

3.6.4 Block Access

The EM405-8 provides a flexible block access feature that can be used to significantly improve data throughput. Both a block read and a block write command is implemented. The flexibility of the block access feature is in the command protocol. The protocol allows the user to specify four parameters in addition to the standard parameters also found in the single data read and write commands: *starting address*, *address increment*, *block size*, and *number of blocks*.

The EM405-8 firmware will execute the command by reading or writing a block of data the size of the *block size* parameter, starting from the *starting address* and ending at:

$$\textit{starting address} + (\textit{block size} * \textit{word size})$$

The firmware will then repeat this process *N* number of times depending on the *number of blocks* parameter. If the *address increment* parameter is not equal to 0, the firmware will increment the starting address by the specified amount after each read or write of a single block.

The M-Module I/O space is a maximum of 256 bytes. Care must be taken when performing a block access that an address greater than 0xFF is never accessed. Otherwise, an error will occur and the block access will terminate immediately.

The following examples further illustrate the block access feature.

Example 1: Read a single block of 32 words (64 bytes) starting at address 0x4.

starting address = 0x4
block size = 32
number of blocks = 1
address increment = don't care

Example 2: Read 32 words (64 bytes) from a FIFO at address 0x8.

starting address = 0x8
block size = 1
number of blocks = 32
address increment = 0

Example 3: Read 32 words from two FIFOs one at address 0x8 and another at address 0xA

starting address = 0x8
block size = 2
number of blocks = 32
address increment = 0

Example 4: Read 32 words starting at address 0x0 followed by 32 words starting at address 0x80

starting address = 0x0
block size = 32
number of blocks = 2
address increment = 128

3.6.4.1 Block Write command

The Block Write command writes a block of data to an M-Module. The number of bytes written in any given command is equal to:

$$\text{number of bytes} = \text{number of blocks} * \text{block size} * \text{word size}$$

The block write command consists of twelve command bytes and any number (up to 1024) of data bytes. The return value is a single status byte indicating the success of the command.

Command Syntax:

0x45 md as ws au am al iu il bu bl bs d1 d0...

Return:

SC

where

md = module (0 = EM405-8 control, 1 = M-Module 0, 2 = M-Module 1, ...)

as = address space (0 = I/O, 1 = future use)

ws = word size (2 = 16-bit word, other values for future use)

au = starting address upper

am = starting address middle

al = starting address lower

iu = address increment upper (number to increment address after each write)

il = address increment lower (number to increment address after each write)

bu = number of blocks to read upper

bl = number of blocks to read lower

bs = block size in words (i.e., number of words per block)

d1_u = data upper (MSB)

d1_l = data lower (LSB)

... = the number of data bytes = ws × bs × number of blocks

SC = Status Code

Example (values shown hex):

To write the data values 0x1234, 0x5678, 0x9ABC to M-Module A starting at I/O Register 4, send the following command:

Command: cd md as ws au am al iu il bu bl bs d1_u d1_l d2_u d2_l d3_u d3_l

Send: 45 01 00 02 00 00 04 00 02 00 03 01 12 34 56 78 9A BC

Receive: 00 (if successful)

3.6.4.2 Block Read command

The Block Read command reads a block of data from an M-Module. The number of bytes read in any given command is equal to:

$$\text{number of bytes} = \text{number of blocks} * \text{block size} * \text{word size}$$

The block read command consists of twelve command bytes. The return value is the requested number of data bytes followed by a single status byte indicating the success of the command. Note that even if the command fails due to no M-Module response, the requested number of bytes will be returned; however, the data values will not be valid. The status byte will indicate the failure.

Command Syntax:

```
0x55 md as ws au am al iu il bu bl bs
```

Return:

```
d1u d1l ... SC
```

where

md = module (0 = EM405-8 control, 1 = M-Module 0, 2 = M-Module 1, ...)
as = address space (0 = I/O, 1 = future use)
ws = word size (2 = 16-bit word, other values for future use)
au = starting address upper
am = starting address middle
al = starting address lower
iu = address increment upper (number to increment address after each read)
il = address increment lower (number to increment address after each read)
bu = number of blocks to read upper
bl = number of blocks to read lower
bs = block size in words (i.e., number of words per block)
d1_u = data upper (MSB)
d1_l = data lower (LSB)
... = the number of data bytes = ws × bs × number of blocks
SC = Status Code

Example (values shown hex):

To read three data values from a 32-bit FIFO located at I/O Register 6 and 8 on M-Module 1, send the following command:

```
Command: cd md as ws au am al iu il bu bl bs
```

```
Send: 55 02 00 02 00 00 06 00 00 00 03 02
```

```
Receive: da1 db1 dc1 dd1 da2 db2 dc2 dd2 da3 db3 dc3 dd3 00 (if successful)
```

```
Receive: d1u d1l d2u d2l d3u d3l d4u d4l d5u d5l d6u d6l 00 (if successful)
```

where

d1_u, d3_u, d5_u = MSB of register 6

d1_l, d3_l, d5_l = LSB of register 6

d2_u, d4_u, d6_u = MSB of register 8

d2_l, d4_l, d6_l = LSB of register 8

Note: d1 is first read, d2 is second read, d3 is third read, and so on.

3.6.5 EM405-8 Configuration/Status Registers

The EM405-8 contains a set of registers that are used to identify the carrier, configure the carrier, and retrieve status from the carrier. These registers are independent of the M-Modules residing on the board. Table III summarizes the register map. Bit level details of each register can be found in Figure 11. These registers are accessed using the **Read Data** and **Write Data** commands with the module field of the command set to '0'.

Table III. Register Summary

Offset	Register
0x00	Reset Error & Manufacturer Identification
0x02	Device Identification
0x04	Hardware Version
0x06	Firmware Version
0x08	Reset Control
0x0A	Fan Control & Temperature Status (Fan Area)
0x0C	Temperature Status (Carrier Logic Area)
0x0E	Temperature Status (M-module Area)
0x10-0x1F	M-module Trigger A Control
0x20-0x2F	M-module Trigger B Control
0x30-0x3F	LVDS Trigger Control
0x40-0x4F	LAN Trigger Control
0x50	External Input TTL Trigger Control
0x52	External Input TTL Trigger Control
0x54	Software Input Trigger Control
0x56	Software Output Trigger Control
0x58	Edge Clock 0 & 1 Source Control
0x5A	Edge Clock 2 & 3 Source Control

Note: Registers 0x10 through 0x5A are only available on the -0001/3 version.

Reset Error & Manufacturer Identification (0x00): A read of this register will return the 12-bit manufacturer ID value of the EM405 and the reset error bit. The manufacturer ID field is read-only. Writing a '1' to the reset error bit will clear the error condition. Refer to section 3.6.1 for details on error handling.

Device Identification (0x02): This read-only register returns the device ID of the EM405-8.

Hardware Version (0x04): This read-only register returns the hardware logic version number of the EM405-8 being accessed.

Firmware Version (0x06): This read-only register returns the firmware version number of the EM405-8 being accessed.

Reset Control (0x08): This read/write register can be used to reset the M-Modules residing on the EM405-8. An independent reset bit is available for each module. Writing a '1' to a reset bit

will assert the hardware reset line for the associated m-module. Writing '0' will return the module back to normal operation.

Fan Control & Temperature Status (0x0A): A read of this register will return a value representative of the temperature inside the EM405-8 around the fan area and will return the current setting of the fan control bit. The temperature field of this register is read only. By writing to the fan control bit, the user can select whether the fan is set to full-on or variable speed.

Temperature Status (0x0C & 0x0E): A read of these registers will return a value representative of the temperature inside the EM405-8 around the control logic and M-Module area, respectively. The registers are read only.

M-Module Trigger A Control (0x10 to 0x1F): (-0001/3 version only) These registers control the direction, conditioning, source type, and source of the M-Module Trigger A signals.

M-Module Trigger B Control (0x20 to 0x2F): (-0001/3 version only) These registers control the direction, conditioning, source type, and source of the M-Module Trigger A signals.

LVDS Trigger Control (0x30 to 0x3F): (-0001/3 version only) These registers control the direction, conditioning, output mode, source type and source of the LVDS triggers.

LAN Trigger Control (0x40 to 0x4F): (-0001/3 version only) These registers control the direction, conditioning, source type and source of the LAN triggers.

External Input TTL Trigger Control (0x50): (-0001/3 version only) This register controls the threshold level, impedance and source type of the input TTL trigger.

External Output TTL Trigger Control (0x52): (-0001/3 version only) This register controls the source of the output TTL trigger.

Software Input Trigger Control (0x54): (-0001/3 version only) This register controls the conditioning of the input software trigger.

Software Output Trigger Control (0x56): (-0001/3 version only) This register controls the source of the software output trigger.

Edge Clock Source Control (0x58 & 0x5A): (-0001/3 version only) These registers control the source of the Edge Clocks. The Edge Clocks are used for edge sensitive triggering.

Reset Error & Manufacturer Identification

Reg. 00	1								0							
Byte																
Bit	15	14	13	12	11	10	9	8	7	6	5	4	3	2	1	0
Write	RERR	-	-	-	Read Only											
Read	RERR	0	0	0	MID											

RERR ⇒ Reset Error (writing a 1 clears the error condition) ¹
MID ⇒ Manufacturer ID (always FC₁₆ - C&H)

Notes:

1. This bit is set if a command error occurs. The RERR bit can be cleared by writing a 1 to this bit. See 3.6.1 for further details.

Device Identification

Reg. 02	3								2							
Byte																
Bit	15	14	13	12	11	10	9	8	7	6	5	4	3	2	1	0
Write	-	-	-	-	Read Only											
Read	0	0	0	0	DID											

DID ⇒ Device ID (always FD_{9₁₆} - EM405-8)

Hardware Version

Reg. 04	5								4							
Byte																
Bit	15	14	13	12	11	10	9	8	7	6	5	4	3	2	1	0
Write	Read Only								Read Only							
Read	HW Major								HW Minor							

HW Major ⇒ Major Version Level of EM405-8 Hardware Logic
HW Minor ⇒ Minor Version Level of EM405-8 Hardware Logic

Firmware Version

Reg. 06	7								6							
Byte																
Bit	15	14	13	12	11	10	9	8	7	6	5	4	3	2	1	0
Write	Read Only								Read Only							
Read	FW Major								FW Minor							

FW Major ⇒ Major Version Level of EM405-8 Firmware
FW Minor ⇒ Minor Version Level of EM405-8 Firmware

Figure 11. EM405-8 Registers

Reset Control

Reg. 08	9								8							
Byte																
Bit	15	14	13	12	11	10	9	8	7	6	5	4	3	2	1	0
Write	Not Used								RST7	RST6	RST5	RST4	RST3	RST2	RST1	RST0
Read	Not Used								RST7	RST6	RST5	RST4	RST3	RST2	RST1	RST0

RSTx ⇒ Reset M-Module x (0 = normal, 1 = reset)

Note: This bit must be cleared by user software to return the M-Module to normal operation. The reset bit need only be set to a 1 for a minimum of 1µs to properly reset an M-Module.

Fan Control & Temperature Status (Fan Area)

Reg. 0A	B								A							
Byte																
Bit	15	14	13	12	11	10	9	8	7	6	5	4	3	2	1	0
Write	VARF	-	-	-	-	-	Read Only									
Read	VARF	0	0	0	0	0	TEMPA									

VARF ⇒ Variable Speed Fan (0 = variable, 1 = full ON)

TEMPA ⇒ Temperature of sensor in the fan area (if bit 9 = 0 then °C = TEMPA / 4, if bit 9 = 1 then °C = -(TEMPA - 1536) / 4)

Note: The VARF bit retains the setting during power off. To use the variable fan feature, it must only be set to variable one time. The original factory default is Full ON.

Temperature Status (Carrier Logic Area)

Reg. 0C	D								C							
Byte																
Bit	15	14	13	12	11	10	9	8	7	6	5	4	3	2	1	0
Write	-	-	-	-	-	-	Read Only									
Read	0	0	0	0	0	0	TEMPB									

TEMPB ⇒ Temperature of sensor in the main logic area of the carrier (if bit 9 = 0 then °C = TEMPB / 4, if bit 9 = 1 then °C = -(TEMPB - 1536) / 4)

Temperature Status (M-module Area)

Reg. 0E	F								E							
Byte																
Bit	15	14	13	12	11	10	9	8	7	6	5	4	3	2	1	0
Write	-	-	-	-	-	-	Read Only									
Read	0	0	0	0	0	0	TEMPC									

TEMPC ⇒ Temperature of sensor in the M-Module area of the carrier (if bit 9 = 0 then °C = TEMPC / 4, if bit 9 = 1 then °C = -(TEMPC - 1536) / 4)

Figure 11. EM405-8 Registers (continued)

Reg. 10	M-Module 0 Trigger A Control															
Byte	11								10							
Reg. 12	M-Module 1 Trigger A Control															
Byte	13								12							
Reg. 14	M-Module 2 Trigger A Control															
Byte	15								14							
Reg. 16	M-Module 3 Trigger A Control															
Byte	17								16							
Reg. 18	M-Module 4 Trigger A Control															
Byte	19								18							
Reg. 1A	M-Module 5 Trigger A Control															
Byte	1B								1A							
Reg. 1C	M-Module 6 Trigger A Control															
Byte	1D								1C							
Reg. 1E	M-Module 7 Trigger A Control															
Byte	1F								1E							
Bit	15	14	13	12	11	10	9	8	7	6	5	4	3	2	1	0
Write	TAEN _x	TAEDGESEL _x	-	TAP _x	TARF _x	TAE _{Lx}	TAD _x	-	TAST _x				-	TASN _x		
Read	TAEN _x	TAEDGESEL _x	0	TAP _x	TARF _x	TAE _{Lx}	TAD _x	0	TAST _x				0	TASN _x		

- TAEN_x ⇒ Enabled (1 = enabled)
TAEDGESEL_x ⇒ EDGECLK Number (only used when direction = input)
TAP_x ⇒ Polarity (0 = normal, 1 = invert)
TARF_x ⇒ Rising/Falling Edge (0 = rising, 1 = falling) (only used when Edge Triggering)
TAE_{Lx} ⇒ Edge/Level Sensitive (0 = edge, 1 = level) (only used when direction = input)
TAD_x ⇒ Direction (0 = input, 1 = output) ¹
TAST_x ⇒ Signal Source Type (only used when direction = output) ²
- | | |
|-------|-----------------------|
| 0 0 0 | External TTL Trigger |
| 0 0 1 | External LVDS Trigger |
| 0 1 0 | M-Module Trigger A |
| 0 1 1 | M-Module Trigger B |
| 1 0 0 | LAN trigger |
| 1 0 1 | reserved |
| 1 1 0 | reserved |
| 1 1 1 | Controller Software |
- TASN_x ⇒ Signal Source Number ³

Notes:

- The direction is with respect to the internal trigger logic. For M-modules, setting the direction to input, means the M-module is expected to drive the trigger. The M-module's internal trigger control logic must be set to output the trigger.
- The specified signal source must be configured as an input for proper operation.
- Not used for External TTL Trigger or Controller Software signal sources.

Figure 11. EM405-8 Registers (continued)

Reg. 20	M-Module 0 Trigger B Control															
Byte	21								20							
Reg. 22	M-Module 1 Trigger B Control															
Byte	23								22							
Reg. 24	M-Module 2 Trigger B Control															
Byte	25								24							
Reg. 26	M-Module 3 Trigger B Control															
Byte	27								26							
Reg. 28	M-Module 4 Trigger B Control															
Byte	29								28							
Reg. 2A	M-Module 5 Trigger B Control															
Byte	2B								2A							
Reg. 2C	M-Module 6 Trigger B Control															
Byte	2D								2C							
Reg. 2E	M-Module 7 Trigger B Control															
Byte	2F								2E							
Bit	15	14	13	12	11	10	9	8	7	6	5	4	3	2	1	0
Write	TBEN _x	TBEDGESEL _x	-	TBP _x	TBRF _x	TBEL _x	TBD _x	-	TBST _x				-	TBSN _x		
Read	TBEN _x	TBEDGESEL _x	0	TBP _x	TBRF _x	TBEL _x	TBD _x	0	TBST _x				0	TBSN _x		

- TBEN_x ⇒ Enabled (1 = enabled)
TBEDGESEL_x ⇒ EDGECLK Number (only used when direction = input)
TBP_x ⇒ Polarity (0 = normal, 1 = invert)
TBRF_x ⇒ Rising/Falling Edge (0 = rising, 1 = falling) (only used when Edge Triggering)
TBEL_x ⇒ Edge/Level Sensitive (0 = edge, 1 = level) (only used when direction = input)
TBD_x ⇒ Direction (0 = input, 1 = output)¹
TBST_x ⇒ Signal Source Type (only used when direction = output)²
- | | |
|-------|-----------------------|
| 0 0 0 | External TTL Trigger |
| 0 0 1 | External LVDS Trigger |
| 0 1 0 | M-Module Trigger A |
| 0 1 1 | M-Module Trigger B |
| 1 0 0 | LAN trigger |
| 1 0 1 | reserved |
| 1 1 0 | reserved |
| 1 1 1 | Controller Software |
- TBSN_x ⇒ Signal Source Number³

Notes:

1. The direction is with respect to the internal trigger logic. For M-modules, setting the direction to input, means the M-module is expected to drive the trigger. The M-module's internal trigger control logic must be set to output the trigger.
2. The specified signal source must be configured as an input for proper operation.
3. Not used for External TTL Trigger or Controller Software signal sources.

Figure 11. EM405-8 Registers (continued)

Reg. 30	LVDS Trigger 0 Control															
Byte	31								30							
Reg. 32	LVDS Trigger 1 Control															
Byte	33								32							
Reg. 34	LVDS Trigger 2 Control															
Byte	35								34							
Reg. 36	LVDS Trigger 3 Control															
Byte	37								36							
Reg. 38	LVDS Trigger 4 Control															
Byte	39								38							
Reg. 3A	LVDS Trigger 5 Control															
Byte	3B								3A							
Reg. 3C	LVDS Trigger 6 Control															
Byte	3D								3C							
Reg. 3E	LVDS Trigger 7 Control															
Byte	3F								3E							
Bit	15	14	13	12	11	10	9	8	7	6	5	4	3	2	1	0
Write	LTEN _x	LTEDGESEL _x	LTOM _x	LTP _x	LTRF _x	LTEL _x	LTD _x	LBIAS _x			LTST _x		-			LTSN _x
Read	LTEN _x	LTEDGESEL _x	LTOM _x	LTP _x	LTRF _x	LTEL _x	LTD _x	LBIAS _x			LTST _x		0			LTSN _x

- LTEN_x ⇒ Enabled (1 = enabled)
- LTEDGESEL_x ⇒ EDGECLK Number (only used when direction = input or output mode = wired-OR)
- LTOM_x ⇒ Output Mode (0 = driven, 1 = wired-OR) (only used when direction = input/output)
- LTP_x ⇒ Polarity (0 = normal, 1 = invert)
- LTRF_x ⇒ Rising/Falling Edge (0 = rising, 1 = falling) (only used when Edge Triggering)
- LTEL_x ⇒ Edge/Level Sensitive (0 = edge, 1 = level) (not used when output mode = driven)
- LTD_x ⇒ Direction (0 = input, 1 = input/output) ¹
- LBIAS_x ⇒ Bias Mode (0 = normal, 1 = Wired-OR bias enabled) ²
- LTST_x ⇒ Signal Source Type (only used when direction = output) ³
- | | |
|-------|-----------------------|
| 0 0 0 | External TTL Trigger |
| 0 0 1 | External LVDS Trigger |
| 0 1 0 | M-Module Trigger A |
| 0 1 1 | M-Module Trigger B |
| 1 0 0 | LAN trigger |
| 1 0 1 | reserved |
| 1 1 0 | reserved |
| 1 1 1 | Controller Software |
- LTSN_x ⇒ Signal Source Number ⁴

Notes:

1. The direction is with respect to the internal trigger logic. For LVDS triggers, setting the direction to output means that the LVDS trigger is driven by the carrier.
2. When Wired-OR Bias mode is enabled, all other configuration bits are ignored and functionally, the trigger line is input only (non-participating). If you would like to configure the device to act as the wired-or bias and to participate in the triggering, set the BIAS mode bit to '0', set the Direction to 'input/output' and set the output-mode to 'driven.'
3. The specified signal source must be configured as an input or wired-OR for proper operation.
4. Not used for External TTL Trigger or Controller Software signal sources.

Figure 11. EM405-8 Registers (continued)

Reg. 40	LAN Trigger 0 Control															
Byte	41								40							
Reg. 42	LAN Trigger 1 Control															
Byte	44								42							
Reg. 44	LAN Trigger 2 Control															
Byte	45								44							
Reg. 46	LAN Trigger 4 Control															
Byte	47								46							
Reg. 48	LAN Trigger 4 Control															
Byte	49								48							
Reg. 4A	LAN Trigger 5 Control															
Byte	4B								4A							
Reg. 4C	LAN Trigger 6 Control															
Byte	4D								4C							
Reg. 4E	LAN Trigger 7 Control															
Byte	4F								4E							
Bit	15	14	13	12	11	10	9	8	7	6	5	4	3	2	1	0
Write	LNEN _x	LNEDGESEL _x	-	LNP _x	LNRF _x	LNEL _x	LND _x	-	LNST _x				-	LNSN _x		
Read	LNEN _x	LNEDGESEL _x	0	LNP _x	LNRF _x	LNEL _x	LND _x	0	LNST _x				0	LNSN _x		

- LNEN_x ⇨ Enabled (1 = enabled)
- LNEDGESEL_x ⇨ EDGECLK Number (only used when direction = input)
- LNP_x ⇨ Polarity (0 = normal, 1 = invert)
- LNRF_x ⇨ Rising/Falling Edge (0 = rising, 1 = falling) (only used when Edge Triggering)
- LNEL_x ⇨ Edge/Level Sensitive (0 = edge, 1 = level) (only used when direction = input)
- LND_x ⇨ Direction (0 = input, 1 = output) ¹
- LNST_x ⇨ Signal Source Type (only used when direction = output) ²
- | | |
|-------|-----------------------|
| 0 0 0 | External TTL Trigger |
| 0 0 1 | External LVDS Trigger |
| 0 1 0 | M-Module Trigger A |
| 0 1 1 | M-Module Trigger B |
| 1 0 0 | LAN trigger |
| 1 0 1 | reserved |
| 1 1 0 | reserved |
| 1 1 1 | Controller Software |
- LNSN_x ⇨ Signal Source Number (direction = output) or EDGECLK Number (direction = input) ³

Notes:

1. The direction is with respect to the internal trigger logic. For LAN triggers, setting the direction to output means that the LAN trigger is sent by the carrier.
2. The specified signal source must be configured as an input for proper operation.
3. When direction = output, this field specifies number of the signal source. When direction = input, this field specifies the EDGECLK number (0-3). Not used for External TTL Trigger or Controller Software signal sources.

Figure 11. EM405-8 Registers (continued)

External Input TTL Trigger Control

Reg. 50	51								50							
Byte																
Bit	15	14	13	12	11	10	9	8	7	6	5	4	3	2	1	0
Write	ITEN	ITEDGESEL	ITLVL	ITP	ITRF	ITEL	ITIMP	-	-	-	-	-	-	-	-	-
Read	ITEN	ITEDGESEL	ITLVL	ITP	ITRF	ITEL	ITIMP	0	0	0	0	0	0	0	0	0

- ITEN ⇒ Enabled (1 = enabled)
- ITEDGESEL ⇒ EDGECLK Number (only used when Edge Triggering)
- ITLVL ⇒ External Input Trigger Threshold Level (0 = +2.5V, 1 = +1.4V)
- ITP ⇒ Polarity (0 = normal, 1 = invert)
- ITRF ⇒ Rising/Falling Edge (0 = rising, 1 = falling) (only used when Edge Triggering)
- ITEL ⇒ Edge/Level Sensitive (0 = edge, 1 = level)
- ITIMP ⇒ External Input Trigger Impedance (0 = high (>900KΩ), 1 = 50Ω)

External Output TTL Trigger Control

Reg. 52	53								52							
Byte																
Bit	15	14	13	12	11	10	9	8	7	6	5	4	3	2	1	0
Write	OTEN	-	-	-	OTP	-	-	-	-	OTST			-	OTSN		
Read	OTEN	0	0	0	OTP	0	0	0	0	OTST			0	OTSN		

- OTEN ⇒ Enabled (1 = enabled)
- OTP ⇒ Polarity (0 = normal, 1 = invert)
- OTST ⇒ Signal Source Type ¹
 - 0 0 0 External TTL Trigger
 - 0 0 1 External LVDS Trigger
 - 0 1 0 M-Module Trigger A
 - 0 1 1 M-Module Trigger B
 - 1 0 0 LAN trigger
 - 1 0 1 reserved
 - 1 1 0 reserved
 - 1 1 1 Controller Software
- OTSN ⇒ Signal Source Number ²

Notes:

1. The specified source must be configured as an input for proper operation.
2. The specific number of the signal source. Not used for External TTL Trigger or Controller Software signal sources.

Figure 11. EM405-8 Registers (continued)

Software Input Trigger Control

Reg. 54

Byte	55								54							
Bit	15	14	13	12	11	10	9	8	7	6	5	4	3	2	1	0
Write	SIENx	-	-	-	SITP	SITRF	SITEL	-	-	-	-	-	-	SITECN		
Read	SIENx	0	0	0	SITP	SITRF	SITEL	0	0	0	0	0	0	SITECN		

- SIENx ⇒ Enabled (1 = enabled)
- SITP ⇒ Polarity (0 = normal, 1 = invert)
- SITRF ⇒ Rising/Falling Edge (0 = rising, 1 = falling) (only used when Edge Triggering)
- SITEL ⇒ Edge/Level Sensitive (0 = edge, 1 = level)
- SITECN ⇒ EDGECLK Number (only used when Edge Triggering)

Software Output Trigger Control

Reg. 56

Byte	57								56							
Bit	15	14	13	12	11	10	9	8	7	6	5	4	3	2	1	0
Write	SOENx	-	-	-	SOTP	-	-	-	-	SOTST			-	SOTSN		
Read	SOENx	0	0	0	SOTP	0	0	0	0	SOTST			0	SOTSN		

- SOENx ⇒ Enabled (1 = enabled)
- SOTP ⇒ Polarity (0 = normal, 1 = invert)
- SOTST ⇒ Signal Source Type¹
 - 0 0 0 External TTL Trigger
 - 0 0 1 External LVDS Trigger
 - 0 1 0 M-Module Trigger A
 - 0 1 1 M-Module Trigger B
 - 1 0 0 LAN trigger
 - 1 0 1 reserved
 - 1 1 0 reserved
 - 1 1 1 Controller Software
- SOTSN ⇒ Signal Source Number²

Notes:

1. The specified source must be configured as an input for proper operation.
2. The specific number of the signal source. Not used for External TTL Trigger or Controller Software signal sources.

Figure 11. EM405-8 Registers (continued)

Edge Clock 0 & 1 Source Control

Reg. 58

Byte	59								58							
Bit	15	14	13	12	11	10	9	8	7	6	5	4	3	2	1	0
Write	ECEN1	EC1S		-	EC1SN			ECEN0	EC0S		-	EC0SN				
Read	ECEN1	EC1S		0	EC1SN			ECEN0	EC0S		0	EC0SN				

ECEN_x ⇒ Enabled (1 = enabled)

ECxS ⇒ Signal Source Type¹

0 0 0	External TTL Trigger
0 0 1	External LVDS Trigger
0 1 0	M-Module Trigger A
0 1 1	M-Module Trigger B
1 0 0	LAN trigger
1 0 1	reserved
1 1 0	reserved
1 1 1	Controller Software

ECxSN ⇒ Signal Source Number²

Notes:

1. The specified source must be configured as an input for proper operation.
2. The specific number of the signal source. Not used for External TTL Trigger or Controller Software signal sources.

Edge Clock 2 & 3 Source Control

Reg. 5A

Byte	5B								5A							
Bit	15	14	13	12	11	10	9	8	7	6	5	4	3	2	1	0
Write	ECEN3	EC3S		-	EC3SN			ECEN2	EC2S		-	EC2SN				
Read	ECEN3	EC3S		0	EC3SN			ECEN2	EC2S		0	EC2SN				

ECEN_x ⇒ Enabled (1 = enabled)

ECxS ⇒ Signal Source Type¹

0 0 0	External TTL Trigger
0 0 1	External LVDS Trigger
0 1 0	M-Module Trigger A
0 1 1	M-Module Trigger B
1 0 0	LAN trigger
1 0 1	reserved
1 1 0	reserved
1 1 1	Controller Software

ECxSN ⇒ Signal Source Number²

Notes:

1. The specified source must be configured as an input for proper operation.
2. The specific number of the signal source. Not used for External TTL Trigger or Controller Software signal sources.

Figure 11. EM405-8 Registers (continued)

3.7 IVI AND M-MODULE DRIVERS

An IVI Instrument Driver is available for status and control of the EM405-8 carrier. The driver provides full control of carrier functions, such as configuring the trigger logic, reading the temperature sensors, controlling the fans, and reading and writing registers on the M-Modules. M-Modules themselves may also have a device driver that can be used to directly control the various functions of the M-Module. Since the M-Modules contain the primary functionality of the integrated unit, in many cases, the M-Module driver will be used exclusively. Contact the particular M-Module manufacturer for documentation and details on an M-Module driver.

3.8 CONTROLLING THE TRIGGERS

The EM405-8 carrier (-0001/3 version only) implements flexible trigger control capabilities providing the user with many options for using triggers. Although not all M-Modules support triggers, each M-Module position on the EM405-8 carrier can support both of the possible trigger lines (TRIGA & TRIGB) on an M-Module. The function of each M-Module trigger line is fully dependent upon the M-Module. Refer to the particular M-Module's documentation for details. The carrier also provides external TTL level trigger access through two external BNC connectors and LVDS level triggers through double stacked micro-D connectors

Each trigger can be configured to be either an input or output. **The direction is always referenced with respect to the internal trigger control logic.** For example, a trigger produced by an M-Module is referred to as an **input** trigger, because the trigger is an input to the internal trigger control logic. A trigger received by an M-Module is referred to as an **output** trigger, since it is produced by the internal trigger logic. If the trigger is defined as an input, then it can be used to produce a trigger to an M-Module or an external device. A single input trigger can be used to drive any number of output triggers. If a trigger is defined as an output then the source of the trigger must be specified.

The internal trigger logic provides input conditioning and routing of the trigger signals as shown in Figure 12. Each trigger type (Trig A and B for each M-Module, LVDS Triggers 0-7, External TTL level, LAN, or Software) can be simply passed-through (level triggering) or latched on the rising or falling edge (edge triggering) of another signal (EDGECLK). Up to four EDGECLK's can be specified. An EDGECLK can any signal specified as an input. Optionally, the input signal can be inverted. Any signal defined as an input can be used as an output trigger. In addition, the output trigger can be inverted as shown in Figure 13.

TTL level triggering is provided through two external BNC connectors. One connector is for an input trigger and the other is for an output trigger. The TTL input trigger has a software configurable threshold and input impedance. The input threshold is configurable using the TLVL bit in the *TTL Trigger Control* register and can be set to either +1.4 volts or +2.5 volts. The input impedance is configurable using the TIMP bit in the *TTL Trigger Control* register and can be set to either high impedance (>900K Ω) or 50 Ω . The output trigger line has a set output impedance of 50 Ω and a set output drive level of +5V (typical) into a high impedance load.

Eight LVDS triggers are provided through double stacked micro-D connectors. The stacked configuration allows easy daisy chaining and termination of the LVDS triggers to other modules. There is a one-to-one connection of signals on the connectors (i.e., pin 1 is tied to pin 1, pin 2 is tied to pin 2, and so on). Refer to Appendix A for pin-out details. For proper operation, the LVDS triggers must be properly terminated. For proper operation, the LVDS triggers must be properly terminated. Information about connection and termination techniques is available on the LXI Standard website (www.lxistandard.org).

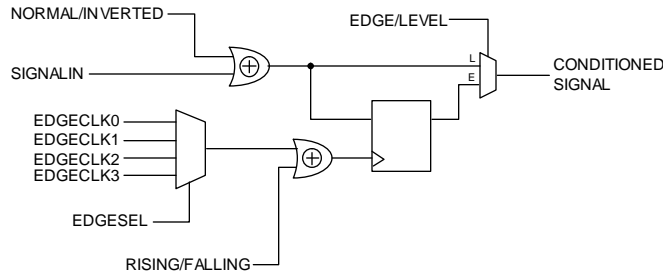

Figure 12. Trigger Logic (Input Direction)

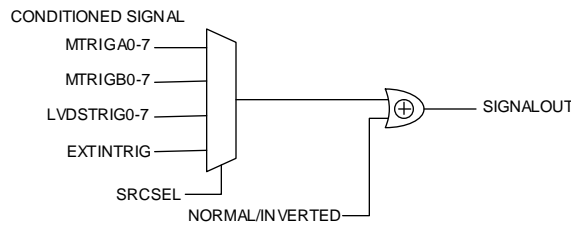

Figure 13. Trigger Logic (Output Direction)

The EM405-8 is capable of providing the LVDS Wired-Or Bias on any or all of the 8 LVDS trigger lines. Wired-Or is a triggering topology in which more than one device can drive a single LVDS trigger line. Detailed information about using Wired-Or triggers on the LXI Wired Trigger Bus is available on the LXI Standard website (www.lxistandard.org). When the LBIAS bit in the *LVDS Trigger Control* register is set to '1' for a particular LVDS trigger line, the EM405-8 is configured to be the Wired-Or Bias device for that trigger. In this mode, all other bits in the *LVDS Trigger Control* register are ignored and the device is configured to continuously provide the Wired-Or Bias signal. Electrically, Wired-Or BIAS mode is equivalent to the device being in 'driven mode' and continuously driving logic '0'. Therefore, it is not immediately apparent, but it is also possible for the EM405-8 to provide the Wired-Or Bias and participate in the Wired-Or Triggering. To do so, simply leave the LBIAS bit set to '0' and operate the device in 'driven mode'. In this mode, the EM405-8 drives a logic '0' (Wired-Or Bias equivalent) on the trigger line when it does not want to assert the line yet when it does want to assert the line it simply drives a logic '1' like normal. All other participating devices on that trigger line must be set to Wired-Or mode.

3.9 FAN AND TEMPERATURE CONTROL

The EM405-8 contains three on-board temperature sensors. One is near the fan input, one is in the area of main carrier control logic, and the other is in the M-Module area. These sensors can be read by reading the three *Temperature Status* registers of the EM405-8. The TEMPx field inside this register represents the current temperature as read by the temperature sensor. To translate the TEMPx value in to degrees Celsius use the following equation:

$$\begin{aligned} \text{If bit 9} = 0 \text{ then } ^\circ\text{C} &= \text{TEMPx} / 4, \text{ and} \\ \text{if bit 9} = 1 \text{ then } ^\circ\text{C} &= -(\text{TEMPB} - 1536) / 4 \end{aligned}$$

The temperature sensors are also read by the firmware and used to control the variable speed fan. When the fan is set to *variable*, the firmware constantly monitors the temperature and increases the fans to Full ON if the temperature gets above a preset level. The variable fan is designed to maintain a maximum 20°C rise in temperature from the ambient inlet air. The user may select the fan to remain full on at all times by setting the VARF bit in the *Fan & Temperature Control* register to a '1'.

APPENDIX A - CONNECTORS

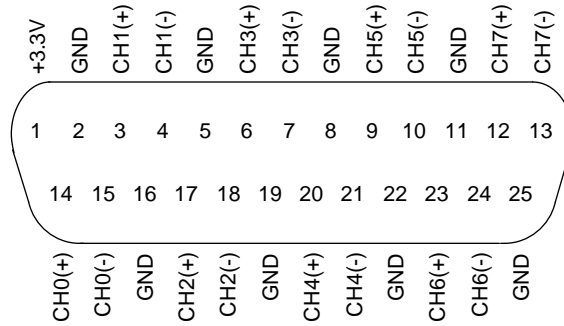

Connector Type: Molex 83619-9011 (Double Stacked)
Pin-outs are the same on both connectors.

Figure A-1. LVDS Micro-D Connector

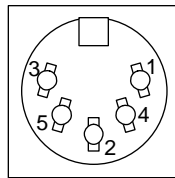

PIN	DESC
1	GND
2	GND
3	+48V
4	GND
5	+48V

Connector Type: Circular 5-position DIN (CUI SDF-50J)

Figure A-2 DC Input Connector

NOTES:

READER'S COMMENT FORM

Your comments assist us in improving the usefulness of C&H's publications; they are an important part of the inputs used for revision.

C&H Technologies, Inc. may use and distribute any of the information that you supply in any way that it believes to be appropriate without incurring any obligation whatsoever. You may, of course, continue to use the information, which you supply.

Please refrain from using this form for technical questions or for requests for additional publications; this will only delay the response. Instead, please direct your technical questions to your authorized C&H representative.

COMMENTS:

Thank you for helping C&H to deliver the best possible product. Your support is appreciated.

Sincerely,

F. R. Harrison
President and CEO

INSTRUCTIONS

In its continuing effort to improve documentation, C&H Technologies, Inc. provides this form for use in submitting any comments or suggestions that the user may have. This form may be detached, folded along the lines indicated, taped along the loose edge (DO NOT STAPLE), and mailed. Please try to be as specific as possible and reference applicable sections of the manual or drawings if appropriate. Also, indicate if you would like an acknowledgment mailed to you stating whether or not your comments were being incorporated.

NOTE: This form may not be used to request copies of documents or to request waivers, deviations, or clarification of specification requirements on current contracts. Comments submitted on this form do not constitute or imply authorization to waive any portion of the referenced document(s) or to amend contractual requirements.

————— (Fold along this line) —————

————— (Fold along this line) —————

Place Stamp Here

C&H Technologies, Inc.
Technical Publications
800 Paloma Drive, Suite 150
Round Rock, Texas 78665